

DANYOU ENGINEERING & TRADING RWANDA LTD

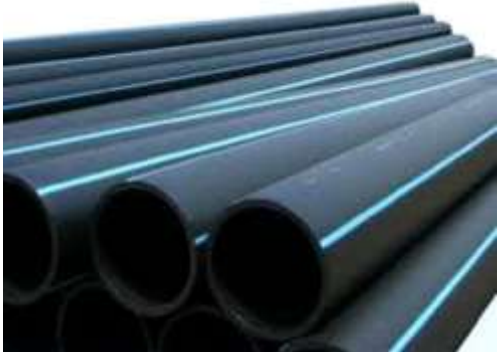

INTRODUCTION

DANYOU ENGINEERS AND INTERNATIONAL SERVICES was formed to cater the needs of Clients in GCC and African region having its Head Office in Mumbai, India and regional office in UAE and Rwanda, Africa. The Company came into existence in 1990 with a team of technocrats having total experience of 50 years in Water & Waste Water, Polyethylene Piping Systems and Other Industrial Products.

During last couple of years, the company has made successful forays in supplying of Equipment's and Services to Clients, EPC Contractors & achieving Success through **Direct Sales, Distributors, Dealers, Agents, Channel Partners, OEMs and Business Associate network** for projects and tender supply for Sector of **Oil & Gas, Utilities, Infrastructure, Industries, Ministries, Power, Real Estate Developers, Water & Waste Water in GCC and African Region** and has integrated the pride of the country while delivering the projects on time through the group company's core activities

DANYOU having a team of technocrats with wide experience in the field of marketing, designing, after sales service and Installation & Commissioning and **It is continuing** the commitment of implementing new technologies, product innovation and technical support and were able to deliver benefits to our customers in the sector of **Oil & Gas, Food Processing Units, Municipal, Industrial, Education units, Commercial, Healthcare, Hospitality, Petroleum, Airports, Seaports Projects, Hotel Industries, Telecommunication and Different Ministries**

DANYOU ENGINEERING & TRADING RWANDA LTD , KIGALI is a part of the **DANYOU GROUP** is a fast growing, professionally managed company in the field of Supply & Services of Desalination Systems, Sewage Treatments Systems, HDPE Pipes, HDPE Fittings, HDPE manholes & Tanks, HDPE Butt Welding Machines, HDPE Extruder machines, Ductile Iron Covers and Gratings, Ductile Iron Pipes and Fittings, Valves, Gaskets, and Related Products, which is ably supported by qualified Engineers & Technicians.

DANYOU is presently working in many African Countries through its office in Rwanda and agents, business associates, dealers and distributors in other African Countries (**Ethiopia, Kenya, Madagascar, Mauritius, Somalia, Sudan, Sudan South, Tanzania, Uganda, Zambia, Zimbabwe and Zanzibar**)



CORPORATE PHILOSOPHY

- ❖ **MISSION:** Striving for excellence in its products representation , services , continues to provide a conducive environment for our employees and staff for professional growth with the ultimate goal of consistently growing quality services and products to an international level to maintain the highest level of customers contentment.
- ❖ **VISION:** Providing unexcelled quality of Service and Products to utmost satisfaction of our customer.
- ❖ **GOAL:** Achieving continuous growth through sustained innovation for total customer satisfaction. Meeting this objective marketing quality products at optimum cost.
- ❖ **MANIFESTO:** Serve and contend through endeavour
- ❖ **PHILOSOPHY:** Commitment to society and environment



HEALTH SAFETY AND ENVIRONMENT

❖ We are committed to ensure a safe and healthy work environment for all personnel and minimize the impact on the local community.



❖ We shall provide systems, training, supervision and visible support to ensure a safe work environment.

❖ We assures that all employees shall have the responsibility to perform their duties in a manner which ensures their own safety and that of others.



QUALITY AND SUPPORT

QUALITY: Commitment to provide the best quality products and services which is demonstrated through our quality assurance teams, installation maintenance teams, product testing facilities and our Quality Guarantee



SUPPORT: Commitment is for innovation, quality and support. We provide unparalleled customer support, training, technical supports of our products. We are committed in helping our customers succeed in every step.



PRODUCT RANGE



A. WATER TREATMENT SYSTEMS

- Reverse Osmosis Systems
- Solar RO Plant
- EDI (Electro De-Ionization)
- Water Softening Plants
- De Mineralization Plants
- Water Filtrations Plants
- Mix Bed Unit
- Chemical Injection System

B.WASTEWATER TREATMENT SYSTEMS

- Grey Water System
- Waste Water Treatment for Automobile Workshop
- Effluent Treatment System
- Ultrafiltration Systems

C.SEWAGE TREATMENT SYSTEMS

- Membrane Bioreactor

- Moving Bed Biofilm Reactor
- Extended Aeration
- Upflow Anaerobic Sludge Blanket
- Activated Sludge Plant
- Rotating Disc System
Submerged Aerated Filter
- Sequencing Batch Reactor

D.DISINFECTION

- Liquid Chlorination System
- Gas Chlorination
- Electro Chlorination
- UV systems
- Ozonator

E. DUCTILE IRON MANHOLES COVERS

F. FRP MANHOLES COVER

G. DI PIPES AND FITTINGS

H. UPVC PIPES ANDFITTINGS

I. HDPE PIPES

J. IRRIGATION PIPES

K.HDPE FITTINGS

L.HDPE MANHOLES

M. GRP TANKS

N.HDPE TANKS

O. VALVES

P. PUMPS

Q. FIRE FIGHTING SYSTEMS

R. D.G.SETS

S. HDPE WELDING MACHINE

T. GI GRATINGS & GUARD RAILS

U. COMMUNICATION TOWERS

V. TRANSFORMERS

WATER TREATMENT SYSTEMS

- Reverse Osmosis Systems
- Solar RO Plant
- EDI (Electro De-Ionization)
- Water Softening Plants
- De Mineralization Plants
- Mix Bed Unit
- Multi Grade Filters
- Pressure Sand Filters
- Activated Carbon Filters
- Filtration Systems
- Chemical Injection System
- Chemical Dosing Systems



REVERSE OSMOSIS SYSTEMS

The reverse osmosis process uses pressure as the driving force
Over come the osmotic pressure of the salt solution service.

TYPES OF RO SYSTEMS

- ❖ TAP WATER RO
- ❖ BRACKISH WATER RO
- ❖ HIGH BRACKISH WATER RO
- ❖ SEAWATER RO

ADVANTAGES

- Continuously operating process, 24 hours a day
- New membranes have high rate of water flow per unit area (flux)
- High overall water recovery rates
- Salt removal, up to 99.8%
- Low power consumption
- Development of energy recovery devices (turbines)
- Minimal cleaning required, longer service



REVERSE OSMOSIS SYSTEMS

TYPES	Tap Water RO TWRO	Brackish Water RO BWRO	Sea Water RO SWRO
Salinity ppm	< 1500	15000 -25000	> 250000
Recovery	80%	65-80%	35-45%
Working Pressure (bar)	< 15	15-25	50-75
Membrane (in)	4 or 8	8	8
Flux(l/h.m ²)	25-30	20-25	15-20
Specific energy at 25°C KWh/hr ³	<0.75	1.5	5
with energy recovery			2-3



SOLAR RO PLANT

- It is not a new concept in water purification industry. solar energy is utilized to power RO systems, which furthermore; generate clean water for drinking purpose. These solar RO water systems can purify water from any source. Water from river, pond or bore well, these solar RO systems can deliver safe drinking water anywhere you need; in addition, these systems are highly suitable for military camps, village areas and Camps and tourist places where arrangement of temporary drinking water is a prime requisite at minimal price.
- Solar Powered Brackish Water Reverse Osmosis
- Solar Powered Sea Water Reverse Osmosis
- Fully automatic units with fold down Solar panel
- All instruments and parts are installed in a container; solar electric panel is fixed top of it or side as convenient. The best feature of such solar RO systems is their 24 hours working without any diesel generator or any expensive power source.



ELECTRO DEIONIZATION

It is a water treatment technology that utilizes an electricity, ion exchange membranes and resin to deionize water and separate dissolved ions (impurities) from water.

It differs from other water purification technologies in that it is done without the use of chemical treatments and is usually a polishing treatment to reverse osmosis (RO).

There are also EDI units that are often referred to as **continuous electro deionization (CEDI)** since the electric current regenerates the resin mass continuously. CEDI technique can achieve very high purity, with conductivity below $0.1 \mu\text{S}/\text{cm}$.

EDI products are used worldwide to produce ultrapure water systems in diverse applications, including power generation, pharmaceutical, semiconductor, petrochemical and laboratory pure water systems



WATER SOFTENING PLANT

Water Softening Plant: is the removal of calcium, magnesium and certain other metal cations in hard water. The resulting soft water is more compatible with soap and extends the lifetime of plumbing. Water softening is usually achieved using ion-exchange resins.

Ion exchange resins are organic polymers containing anionic functional groups to which the divalent cations (Ca^{++}) bind more strongly than monovalent cations (Na^+). These minerals are widely used in laundry detergents. Resins are also available to remove carbonate, bi-carbonate and sulphate ions which are absorbed and hydroxide ions released from the resin.

When all the available Na^+ ions have been replaced with calcium or magnesium ions, the resin must be re-charged by eluting the Ca^{2+} and Mg^{2+} ions using a solution of sodium chloride or sodium hydroxide depending on the type of resin used.¹ For anionic resins, regeneration typically uses a solution of sodium hydroxide (lye) or potassium hydroxide. The waste waters eluted from the ion-exchange column containing the unwanted calcium and magnesium salts are typically discharged to the sewage system.



DE MINERALIZATION SYSTEMS

De Mineralization Plants/De Ionization .as the name explains is a term normally used for reduction of charged ions to very low levels. Deionization is also alternatively called as Demineralization.

The deionization is normally a two stage process. In first stage the cations & in second stage anions are removed respectively. Sometimes a polisher unit called mixed bed is also employed when the water quality requirement is stringent.

There are variations in column design. In vessel configuration, the two basic types are down flow & Up flow design. In Downflow vessels regeneration is carried out in two methods

1. Co-Flow Unit – The regenerant flows in same direction as that of water.
2. Counter-Flow Unit – In this design the regenerant flows in opposite direction as that of water. This method is usually envisaged where very low leakage levels are expected. The very large polishers have external regeneration systems also. The required scheme is normally decided based on feed water quality, outlet quality required and flow rate between two regenerations.



MIXED BED UNITS

A mixed bed exchanger has both cation and anion resin mixed together in a single vessel. As water flows through the resin bed, the ion exchange process is repeated many times, "polishing" the water to a very high purity. During regeneration, the resin is separated into distinct cation and anion fractions .

The resin is separated by backwashing, with the lighter anion resin settling on top of the cation resin. Regenerant acid is introduced through the bottom distributor, and caustic is introduced through distributors above the resin bed.

The regenerant streams meet at the boundary between the cation and anion resin and discharge through a collector located at the resin interface. Following regenerant introduction and displacement rinse, air and water are used to mix the resins. Then the resins are rinsed, and the unit is ready for service.

Counterflow mixed bed systems produce a purer water than conventional cation-anion demineralizers, but require more sophisticated equipment and have a higher initial cost. The more complicated regeneration sequences require closer operator attention than standard systems. This is especially true for a mixed bed unit.



MULTI GRADE FILTERS

MULTI GRADE FILTER is a depth filter that makes use of coarse and fine media mixed together in a fixed proportion.

This arrangement produces a filter bed with adequate pore dimensions for retaining both large and small suspended particles.

This filter performs at a substantially higher specific flow rate than conventional filters.

Specific flow rates have been successfully obtained for treating waters containing 25 – 50 ppm suspended solids respectively to produce filtrate with less than 5 ppm

- Filtration Velocity :6-15m³/hr.m²
- Diameter : 500- 3000mm
- Filtration Area : 0.2- 7m²
- Flow Rates :1-100m³/hr



PRESSURE SAND FILTER

PRESSURE SAND FILTER consists of a multiple layer of **sand** with a variety in size and specific gravity. These **Filters** are designed to remove turbidity and suspended particles present in the feed water with minimum **pressure** drop. These **Filters** are custom designed to suit the process requirement.

The filter will effectively remove up to 30 – 50 microns of the suspended solids to less than 5 ppm. The filter will have to be washed with raw water for 20 to 30 minutes daily. To filter the particles below 30 – 50 micron cartridge filter is used.

- Filtration Velocity :6-15m³/hr.m²
- Diameter : 500- 3000mm
- Filtration Area : 0.2- 7m²
- Flow Rates :1-100m³/hr



ACTIVATED CARBON FILTER

ACTIVATED CARBON FILTER Carbon filtering is a method of filtering that uses a bed of activated carbon to remove contaminants and impurities, using chemical adsorption.

Activated carbon works via a process called adsorption, whereby pollutant molecules in the fluid to be treated are trapped inside the pore structure of the carbon substrate. Carbon filtering is commonly used for water purification, in air purifiers and industrial gas processing, Active charcoal carbon filters are most effective at removing chlorine, sediment, volatile organic compounds(VOCs), taste and odour from water.

Typical particle sizes that can be removed by carbon filters range from 0.5 to 50 micrometres. The particle size will be used as part of the filter description. The efficacy of a carbon filter is also based upon the flow rate regulation. When the water is allowed to flow through the filter at a slower rate, the contaminants are exposed to the filter media for a longer amount of time.

- Filtration Velocity :2-8m³/hr.m²
- Diameter : 500- 3000mm
- Filtration Area : 0.2- 7m²
- Flow Rates : 1- 100m³/hr



FILTRATION SYSTEMS

Iron Removal Filters The process through which **iron** is removed from water is known as Oxidation **Filtration** that involves the oxidation of the soluble forms of **iron** (Fe) and manganese (Mn) to their insoluble forms and then **removal** by **filtration**

- Diameter : 400- 3000mm
- Flow Rates : 1m³/hr -85m³/h

Arsenic Filters There are several methods available for removal of arsenic from water. The following important methods are discussed below: Oxidation , Coagulation , Adsorption , Resins and membrane Technology

- Filtration Velocity : 15-25m³/hr.m²
- Diameter : 500- 3000mm
- Filtration Area : 0.2- 7m²
- Flow Rates : 1- 100m³/hr

Remineralization Filters

- Filtration Velocity : 8-30m³/hr.m²
- Diameter : 500- 3000mm
- Filtration Area : 0.2- 7m²
- Flow Rates : 1- 200m³/hr



CHEMICAL INJECTION SYSTEM

Chemical Injection system: Chemical injection skids inject precise amounts of specific chemicals into a system at required temperatures, pressures and flowrates.

A complete system includes a chemical storage tank, two 100% dosing pumps, instruments, piping, valves, calibration column, pulsation dampeners and a skid structure.

The Chemical Injection Systems are designed to have the following:

Fully automated PLC control & local operator interface.

Precise control logic for maximum efficiency and accuracy.

Single pump or with standby pump option.

Our products

- **Single-Point Chemical Injection Systems**
- **Multi-Point Chemical Injection Systems**
- **Solar-Powered Chemical Injection Systems**
- **Gas-Powered Chemical Injection Systems**
- **Chemical Injection Systems for Extreme Environmental Applications**
- **Chemical Distribution Panels/IRCD**
- **Chemical Pump Skids/Containerised Pump Skids**



CHEMICAL DOSING SYSTEM

Chemical Dosing System is widely applied in corrosion, chlorine dosing, Chemical Dosing , scale inhibitor, coagulation, sterilization and algae removal of the circulating water systems such as air-conditioning cooling water, chilled water, water pipelines, Sewage Treatment, Water Treatment, Ice storage, etc.

The chemical dosing system can also achieve the effect equivalent to the electronic descaling instrument.

In the process of air conditioning circulating water and various purified water, the water quality always decides if the system can run efficiently for a long time.

The pipeline corrosion, scaling, microbial propagation and other common problems of circulating water always disturber the owners



DISINFECTION SYSTEM

Disinfection means the removal, deactivation or killing of pathogenic micro-organisms. Micro-organisms are destroyed or deactivated, resulting in termination of growth and reproduction.

Disinfection can be attained by means of physical or chemical disinfectants. The agents also remove organic contaminants from water, which serve as nutrients or shelters for micro-organisms. Disinfectants should not only kill micro-organisms. Application are

- Public drinking water supply.
- Food and beverage industry.
- Paper industry.
- Treatment of water in Breweries.
- Pasteurizing and Rinsing in Breweries.
- CIP systems.
- Cooling water treatment.
- Cold sterile bottling.
- Condensate water treatment in the Milk industry.
- In Aqua culture
- Wash water treatment.
- Meat processing industry.



LIQUID CHLORINATION

Chlorine (Cl_2) has been used for many years to treat potable water, municipal and industrial water and waste waters to control microorganisms because of its capacity to inactivate most pathogenic microorganisms quickly. The effectiveness of chlorine is dependent on the chlorine concentration, time of exposure, and the pH of the water. Chlorine is used for treating potable water where a residual chlorine concentration near 0.5 mg/L is commonly used. In an industrial water treatment scheme, fouling of water intake lines, heat exchangers, sand filters, etc., may be prevented by maintaining a free residual chlorine concentration of 0.5–1.0 mg/L or higher, dependent on the organic content of the incoming water.

Calcium Hypochlorite: Calcium hypochlorite is available as granules or tablet form. The tablets can be used with erosion feeder. Tablets are placed in a hopper where they are stored dry. Water is allowed to run past the bottom layer of tablets where slow erosion will occur. The chlorinated water then drops into a buffer storage tank where flushing and dilution occurs. The diluted (<500ppm) solution is continually pumped to the process water header for disinfection. Control of chlorination is by a residual chlorine controller (Chlorine Analyzer). This controller gives a pulse duration control signal to the feeder and the feeder controls the tablet erosion water valve.



ULTRA VOILET SYSTEM

Ultraviolet System(UV) water treatment works by exposing micro-organisms to UV radiation, via a special UV light bulb, which disrupts their DNA and disables their ability to replicate.

UV is Ultraviolet radiation, an energy band within the electromagnetic energy spectrum. It is a colorless, tasteless, odorless and chemical free way to ensure your water supply is safe and clear of germs and other microorganisms that can make you sick.

UV does not affect sediment, particulates or other mineral contaminants which will require additional water treatment methods.

UV is also an effective tool in pond algae control. UV can be used in: homes, cottages, hotels, motels, buildings, factories, rinse processes, bottling plants, food processing, cooling towers, breweries, hospitals, fisheries, farms, wineries Residential, Commercial Industrial applications , sewage treatment plants. , Effluent Treatment , Swimming Pool water disinfection ,Domestic water disinfection , Pharmaceutical applications , Sugar Syrup treatment , Ozone destruction



OZONATOR

Ozonator The Ozonator is a device with an aerator at the end of its hose, which is inserted in the water, oil or food. It adds a tiny amount of ozone and results in a sanitizing and oxidizing effect. Ozone is produced by adding a third atom of oxygen to a molecule, i.e. O₃ instead of the usual O₂.

Ozone is an unstable gas comprising of three oxygen atoms, the gas will readily degrade back to oxygen, and during this transition a free oxygen atom, or free radical form. The free oxygen radical is highly reactive and short lived, under normal conditions it will only survive for milliseconds

Ozone has a greater disinfection effectiveness against bacteria and viruses compared to chlorination. In addition, the oxidizing properties can also reduce the concentration of iron, manganese, sulphur and reduce or eliminate taste and odor problems. Ozone oxidizes the iron, manganese, and sulphur in the water to form insoluble metal oxides or elemental sulphur. These insoluble particles are then removed by post-filtration



WASTE WATER TREATMENT SYSTEMS

- ❖ Waste Water Treatment for Automobile Workshop
- ❖ Effluent Treatment System
- ❖ Ultrafiltration Systems
- ❖ Grey Water Treatment system
- ❖ Grey + Sewage Treatment system



WASTE WATER SYSTEMS FOR CAR WORKSHOP

Waste Water Treatment for Automobile Workshop: This purification system is installed in car wash services and industrial activities with the presence of surfactants in waste water process. It is also used for grey waters, coming from kitchens and showers. The purified water can be reused, in the industrial process, for watering gardens

The system can be realized in various steps depending on the real needs of water reuse.

PRE-TREATMENT

OXYGENATION

FILTRATION AND ABSORPTION

SECONDARY OXYGENATION



Ultrafiltration Systems: (UF) is a variety of membrane filtration in which forces like pressure or concentration gradients lead to a separation through a semipermeable membrane. Ultrafiltration is applied in cross-flow or dead-end mode.

Application

- Drinking water
- Protein concentration
- Filtration of effluent from paper pulp mill
- Cheese manufacture,
- Removal of pathogens from milk
- Process and waste water treatment
- Enzyme recovery
- Fruit juice concentration and clarification
- Dialysis and other blood treatments
- Desalting and solvent-exchange of proteins (via diafiltrating)
- Laboratory grade manufacturing



EFFLUENT TREATMENT SYSTEM

Effluent Treatment System: Effluent Water treatment processes for separating physical, chemical and biological contaminants and pathogens from discarded wastewater; treating sludge and controlling aquatic odours to **extract the full value from wastewater resources.**

Effluent water can be upgraded to **process, or potable water standards.** By refining discarded effluent, Effluent Water treatment processes help municipalities and industries reduce reliance on increasingly undependable natural water sources and instead produce environmentally benign effluent and solid waste (treated sludge) that can be re-used for a variety of applications. This helps to **lower and control capital costs, reduce operational carbon footprint** and **enhance sustainability** to preserve Environment The solutions are available for

- Industrial Effluent Water Treatment,
- Municipal Effluent Water Treatment for industry,
- Effluent Water Treatment Package Plants,
- Industry-specific Wastewater Treatment Chemicals and Technologies.



TREATMENT OF INDUSTRIAL WASTE-WATER

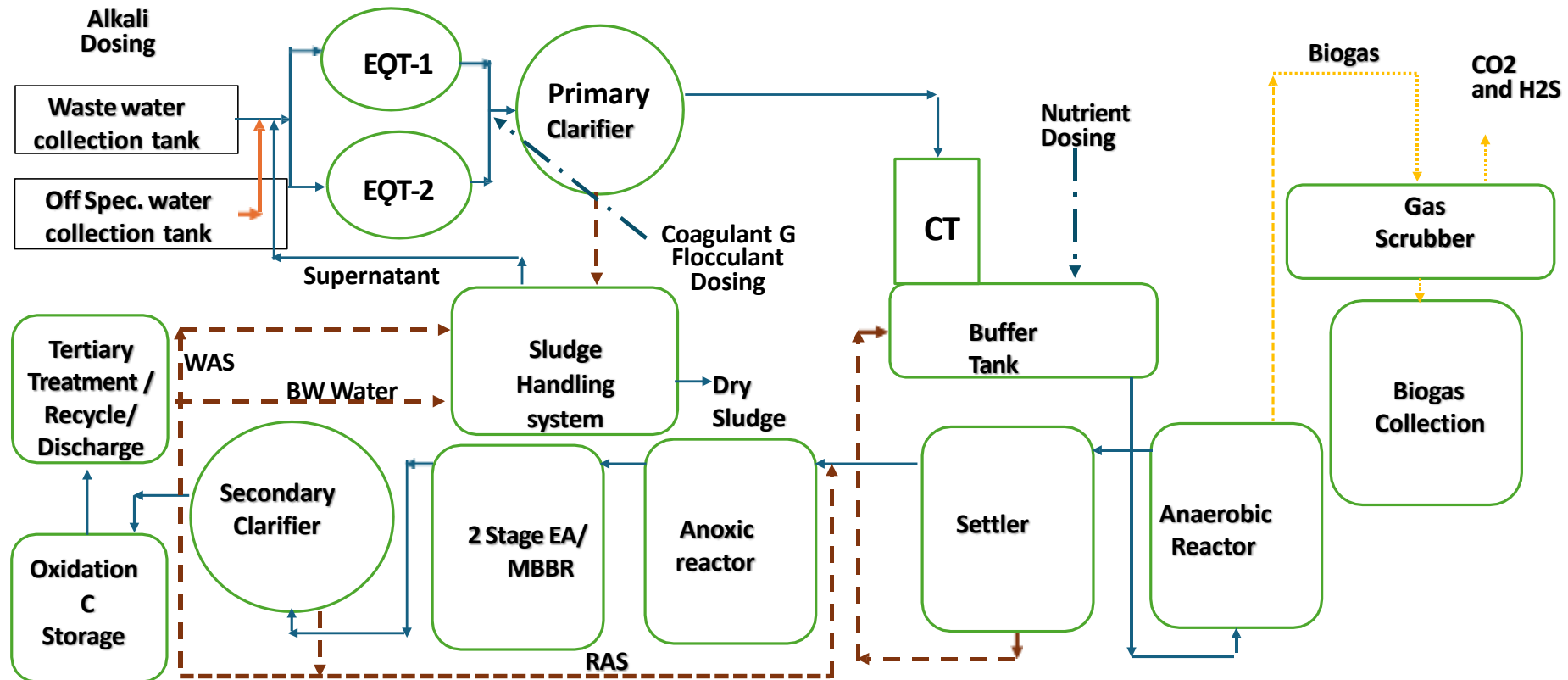

RECYCLING & ZERO DISCHARGE INDUSTRIAL EFFLUENT

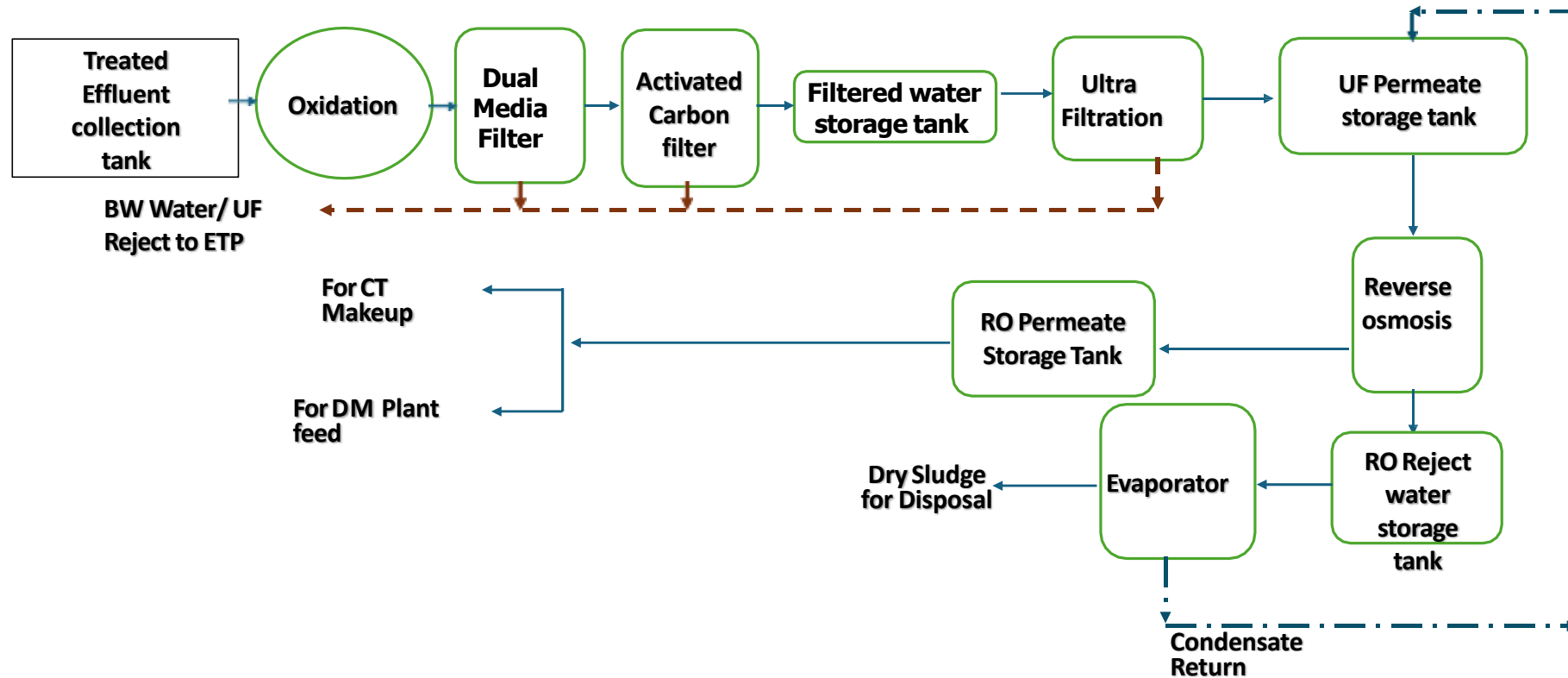

TYPE OF SEWAGE TREATMENT SYSTEMS



SEWAGE TREATMENT SYSTEMS

SEWAGE TREATMENT SYSTEMS is the process of removing contaminants from wastewater, primarily from household sewage. It includes physical, chemical, and biological processes to remove these contaminants and produce environmentally safe treated wastewater (or treated effluent). A by-product of sewage treatment is usually a semi-solid waste or slurry, called sewage sludge, that has to undergo further treatment before being suitable for disposal or land application.

- Package Sewage Treatment Systems
- Membrane Bio Reactor (MBR)
- Moving Bed Biofilm Reactor (MBBR)
- Extended Aeration
- Sequencing Batch Reactor (SBR)
- Submerged Aerated Filter (SAF)
- Activated Sludge Plant (ASP)
- Up Flow Anaerobic Sludge Blanket (UASB)
- Rotating Disc System.
- Odour Control System
- Trickling Filter



GREY WATER SYSTEMS

Grey Water System: Greywater is waste water generated in households or office buildings from streams without Sewage contamination. As greywater contains fewer pathogens than domestic wastewater, it is generally safer to handle and easier to treat and reuse onsite for toilet flushing, landscape or crop irrigation, and other non-potable uses.

The use of non-toxic and low-sodium soap and personal care products is recommended to protect vegetation when reusing greywater for irrigation purposes.

The application of greywater reuse in urban water systems provides substantial benefits for both the water supply subsystem by reducing the demand for fresh clean water as well as the wastewater subsystems by reducing the amount of wastewater required to be conveyed and treated.

Greywater, by definition, does not include the discharge of toilets or highly contaminated Sewage waste water, which is designated sewage or blackwater to indicate it contains human waste. The small traces of Sewage that enter the greywater stream via effluent from the shower, sink, or washing machine do not pose practical hazards under normal conditions, as long as the greywater is used correctly



GREY + SEWAGE WATER TREATMENT

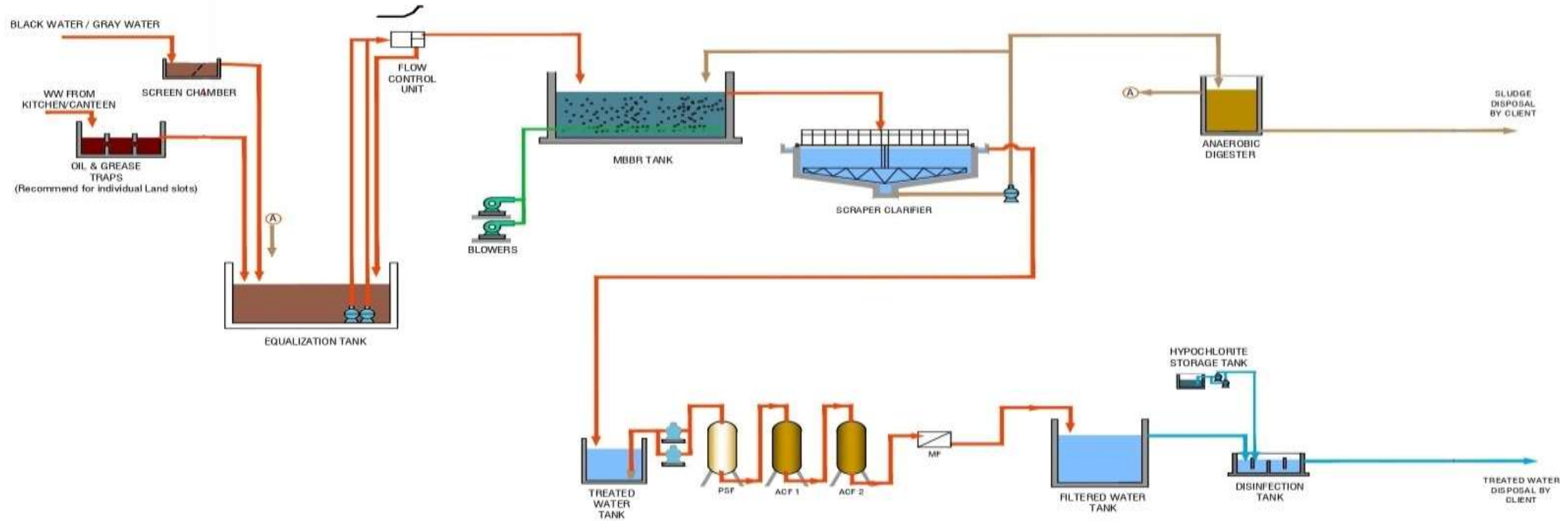

PACKAGE SEWAGE TREATMENT SYSTEM

PACKAGE SEWAGE TREATMENT SYSTEMS are designed to the particular needs of each location. Suitable for permanent or temporary use in areas outside municipal wastewater systems

ADVANTAGES

- Pre-assembled, skid-mounted and factory-tested packaged systems have less requirements for installation and reduced onsite construction costs.
- Compact designs for easy integration into existing facilities
- Completed engineering packages with quick delivery
- Comprehensive cleaning capabilities for peak systems performance
- Simple operation and maintenance requires minimal operator supervision.



MEMBRANE BIO REACTORS

Membrane Bioreactor (MBR) defines a combination of an activated sludge process and WW separation by means of membranes

The popularity of MBR technology lies in following advantages: over conventional processes

- Most important aspect of MBR technology is production of very high quality effluent consistently.
- Compliance with International stringent discharge norms.
- Complete independent control of HRT (Hydraulic Retention Time) and SRT (Sludge Retention Time), which allow more complete reduction of COD, and improved stability of processes such as nitrification.
- Reduced Sludge Production
- Process intensification through high Biomass concentration with MLSS (Mixed Liquor Suspended Solids) over 8000 – 10000 ppm.
- Ability to treat high strength wastewater.
- Lower footprint than Conventional Activated Sludge Process, since Clarifier/Filters are eliminated.
- Reduction in Post disinfection requirements.



MOVING BED BIOFILM REACTOR

Moving Bed Biofilm Reactor The MBBR system consists of an aeration tank with special plastic carriers that provide a surface where a biofilm can grow. The carriers are made of a material with a density close to the density of water (1 g/cm^3).

The carriers will be mixed in the tank by the aeration system and thus will have good contact between the substrate in the influent wastewater and the biomass on the carriers.

The MBBR system is often installed as a retrofit of existing activated sludge tanks to increase the capacity of the existing system. The degree of filling of carriers can be adapted to the specific situation and the desired capacity. Thus, an existing treatment plant can increase its capacity without increasing the footprint by constructing new tanks.

Higher effective sludge retention time (SRT) which is favourable for nitrification

Responds to load fluctuations without operator intervention

Lower sludge production

Less area required

Resilient to toxic shock

Process performance independent of secondary clarifier



EXTENDED AERATION

EXTENDED AERATION SYSTEMS are a method of sewage treatment using modified activated sludge procedures. It is preferred for relatively small waste loads, where lower operating efficiency is offset by mechanical simplicity.

Extended aeration agitates all incoming waste in the sludge from a single clarifier. The combined sludge starts with a higher concentration of inert solids than typical secondary sludge and the longer mixing time required for digestion of primary solids in addition to dissolved organics produces aged sludge requiring greater mixing energy input per unit of waste oxidized.

Extended aeration is typically used in prefabricated "package plants" intended to minimize design costs for waste disposal from small communities, tourist facilities, or schools



SEQUENCING BATCH REACTOR

Sequencing batch reactor (SBR) The Sequencing Batch Reactor (SBR) is an activated sludge process designed to operate in a batch mode with aeration and sludge settlement both occurring in the same tank.

SBR process is a unique combination of equipment and software. Working with automated control reduces the number of operator skill and attention requirement. There are basically five stages to treatment: Fill, React, Settle, Decant and Idle

Advantages of Sequencing Batch Reactor

- Small footprint
- Simple Design.
- Maintains consistent effluent quality due to batch settling method.
- Suitable for variable organic and hydraulic load.
- No Clarifier required reducing the spare requirement
- Effective quiescent settling
- No sludge recirculation
- Biological Nutrient removal.



SUBMERGED AERATED FILTERS

Submerged aerated filter (SAF) The submerged aerated filter (SAF) they have a settling tank to clarify the solids that slough from the filter rather than using back-washing. The plant has a 1-4m deep bed of filter media on which to grow a biomass.

A blower sends air to the bottom of the bed to provide oxygen for the biomass to support the oxidation process. The air stream promote There are lots of SAF variants

Combination system have an upstream aerated compartment with a random particulate medium restrained by a mesh across the outlet of the chamber and a downstream chamber which, is also aerated, containing a modular plastic medium.

Loop reactor system feature circular tanks constructed with a central riser pipe with an aerator mounted centrally beneath the pipe. The up flow of air causes the wastewater to flow upwards through the riser pipe and then fall down through the annular space within the tank through a plastic filter medium.

Compartmentalised system The tank can also be com compartmentalised such that the flow of effluent through the tanks is upward through one chamber of medium, downward through the next and so-on. The aerators are positioned at the base of alternate vertical columns of medium to promote the rising and falling columns of wastewater. Recirculation of the effluent is achieved by providing free space at the top and bottom of the reactor beds of medium.as both efficient mixing of the effluent and disturbance of any excess solids from the filter medium.



ACTIVATED SLUDGE PLANT

Activated sludge plant (ASP): The **activated sludge** process is a process for treating sewage and industrial wastewaters using air and a biological floc composed of bacteria and protozoa.

The general arrangement of an activated sludge process for removing carbonaceous pollution includes the following items:

Aeration tank where air (or oxygen) is injected in the mixed liquor.

Settling tank (usually referred to as "final clarifier" to allow the biological flocs (the sludge blanket) to settle, thus separating the biological sludge from the clear treated water.

Treatment of nitrogenous matter or phosphate involves additional steps where the mixed liquor is left in anoxic condition

The general method to do this is to monitor sludge blanket level, SVI (Sludge Volume Index), MCRT (Mean Cell Residence Time), F/M (Food to Microorganism), as well as the biota of the activated sludge and the major nutrients DO (Dissolved oxygen, nitrogen, phosphate, BOD (Biochemical oxygen demand) and COD (Chemical oxygen demand).



UP FLOW ANAEROBIC SLUDGE BLANKET

Up flow anaerobic sludge blanket (UASB) technology, normally referred to as UASB reactor, is a form of anaerobic digester that is used for wastewater treatment. The UASB reactor is a methanogenic (methane-producing) digester that evolved from the anaerobic clarifier. A similar but variant technology to UASB is the expanded granular sludge bed (EGSB digester).

UASB uses an anaerobic process whilst forming a blanket of granular sludge which suspends in the tank. Wastewater flows upwards through the blanket and is processed (degraded) by the anaerobic microorganisms. The upward flow combined with the settling action of gravity suspends the blanket with the aid of flocculants. The blanket begins to reach maturity at around three months. Small sludge granules begin to form whose surface area is covered in aggregations of bacteria. In the absence of any support matrix, the flow conditions create a selective environment in which only those microorganisms capable of attaching to each other survive and proliferate. Eventually the aggregates form into dense compact biofilms referred to as "granules".

UASB reactors are typically suited to dilute waste water streams (3% TSS with particle size $>0.75\text{mm}$).

Design with UASB, the process of settlement and digestion occurs in one or more large tank(s). The effluent from the UASB, which has a much reduced biochemical oxygen demand (BOD) concentration, usually needs to be treated further, for example with the activated sludge process, depending on the effluent quality requirements.



ROTATING BIOLOGICAL CONTACTORS

Rotating Biological Contactor. RBC is a biological treatment process used in the treatment of wastewater following primary treatment. The primary treatment process removes the grit and other solids through a screening process followed by a period of settlement.

The RBC process involves allowing the wastewater to come in contact with a biological medium in order to remove pollutants in the wastewater before discharge of the treated wastewater to the environment, usually a body of water (river, lake or ocean).

The rotating packs of disks (known as the media) are contained in a tank or trough and rotate at between 2 and 5 revolutions per minute. Commonly used plastics for the media are polyethylene, PVC and expanded polystyrene. The discs consist of plastic sheets ranging from 2 to 4 m in diameter and are up to 10 mm thick.

Biological growth is attached to the surface of the disc and forms a slime layer. The discs contact the wastewater with the atmospheric air for oxidation as it rotates. The rotation helps to slough off excess solids. The disc system can be staged in series to obtain nearly any detention time or degree of removal required. Since the systems are staged, the culture of the later stages can be acclimated to the slowly degraded materials.



ODOUR CONTROL SYSTEMS

Odour Control System Odour is obnoxious smell that offends human olfactory organs. Normally gases like Hydrogen Sulphide, Indole, Skatole, Mercaptans, Methyl Amine etc. emits typical sewage odours. The threshold value for H₂S is considered to be in the range of 0.05 – 12 ppmv, which is why even very small quantity is noticeable.

The odour control or air treatment is done by passing the polluted air through the bed of specially designed Activated carbon.

The air in the sewage lift station is sucked by an induced draft Fan into Carbon Filter, where the sucked air is passed through carbon bed. The carbon bed adsorbs the various gases like Hydrogen Sulphide, Indole, Skatole, Mercaptans, Methyl Amine etc. on to the surface of the carbon.

The Activated carbon is specially engineered to have mesoporous as well as macroporous nature to have maximum area available for Chemisorption of odour producing gases.



TRICKLING FILTER

Trickling filter. A trickling filter is a type of wastewater treatment. It consists of a fixed bed of rocks, lava, coke, gravel, slag, polyurethane foam, sphagnum peat moss, ceramic, or plastic media over which sewage/ other wastewater flows downward and causes a layer of microbial slime.

Aerobic conditions are maintained by splashing, diffusion, and either by forced-air flowing through the bed or natural convection of air if the filter medium is porous.

These systems have also been described as roughing filters, intermittent filters, packed media bed filters, alternative septic systems, percolating filters, attached growth processes, and fixed film processes.

A typical trickling filter is circular and between 10 metres and 20 metres across and between 2 metres to 3 metres deep.

Single trickling filters may be used for the treatment of small residential septic tank discharges and very small rural sewage treatment systems. Larger centralized sewage treatment plants typically use many trickling filters in parallel.

Multi-pass systems result in higher treatment quality and assist in removing Total Nitrogen (TN) levels by promoting nitrification in the aerobic media bed and denitrification in the anaerobic septic tank.



BIOGAS SYSTEMS

- ❖ A cattle farm biogas system captures methane from manure to produce energy, but raw biogas contains impurities like carbon dioxide (CO_2) and hydrogen sulphide (H_2S) that must be removed via scrubbing to prevent engine corrosion and increase heating value.
- ❖ **Water Scrubbing (Physical Absorption):** The most common method due to its simplicity and low cost. Raw biogas is compressed and fed into the bottom of a vertical column while water sprays from the top. CO_2 and H_2S dissolve into the water, leaving purified methane (up to 92-98% purity) to exit the top.
- ❖ **Feedstock Ratio:** Roughly **22 kg of cow dung** is needed to produce 1 kg of biogas; typically mixed with water in a 1:1 ratio.
- ❖ **Energy Consumption:** Water scrubbing systems consume about **0.24 to 0.37 kWh per cubic meter** of biogas, with the lowest specific energy consumption often found at an operating pressure of around **2 bar**.
- ❖ **Upgrading for Fuel:** To use biogas as vehicle fuel (Bio-CNG), it must be scrubbed to >92% methane and then compressed to approximately **200–250 bar**

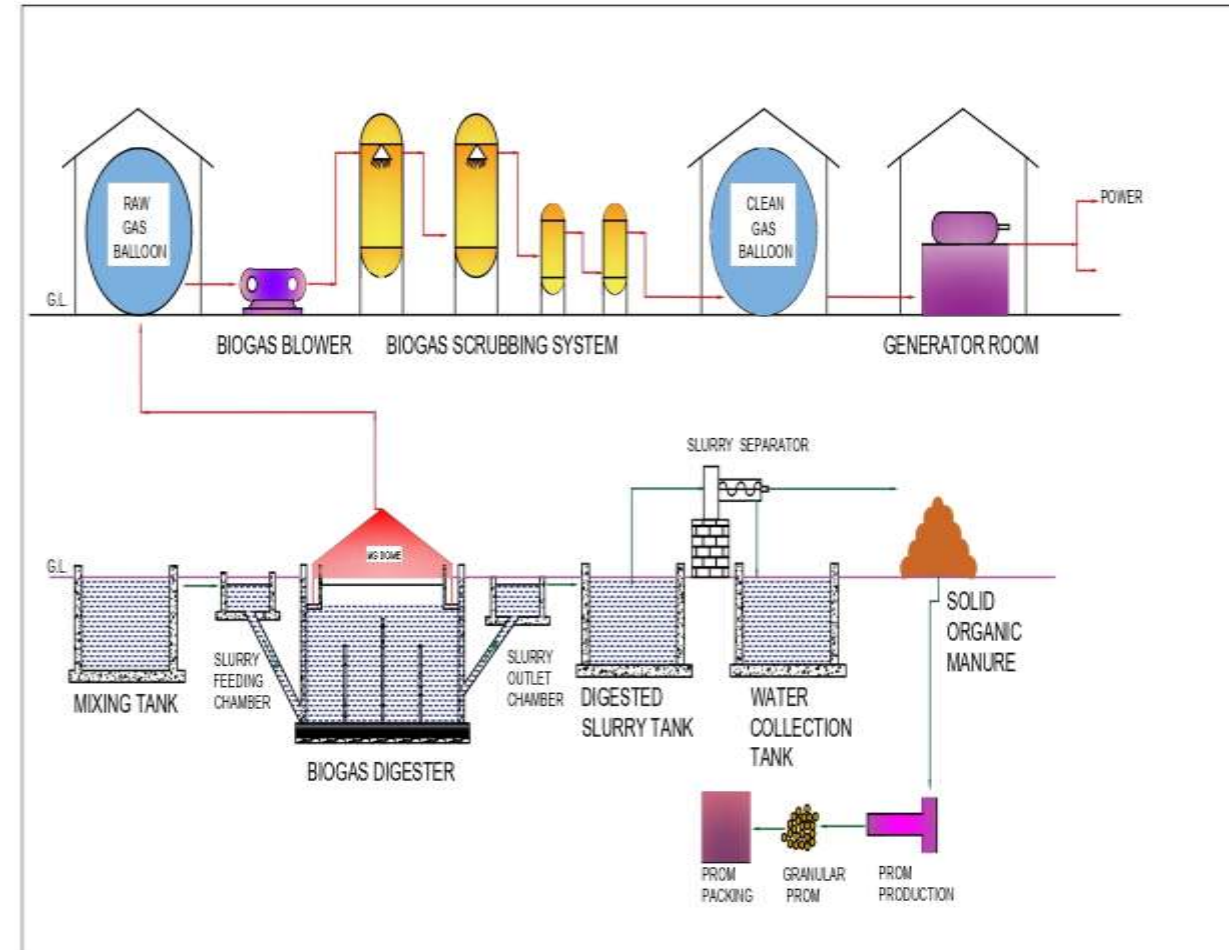

DUCTILE IRON MANHOLE COVERS

DUCTILE IRON MANHOLE COVER: Spheroid Graphite' or 'Ductile Iron' is a unique form of Iron. which prior to the metal casting process receives crucial mineral additives to produce an exceptionally strong resistance and durable metal, the molecular structure of 'Ductile Iron' gives rise to excellent additional strength and shock load resistance, within structure carbon steel, without steel inheriting corrosion. In today's roads, Covers & Gratings are required to carry increasingly heavy and fast moving traffic, yet the need to keep the roads in service, places free from accidents and theft, additional demands on those Covers and Gratings in terms of speed and ease of access for maintenance of services is essential. 'Ductile Iron' Manhole Covers, Gratings and Frames are fast replacing the conventional 'Grey Iron Manhole Covers, Gratings and Frames on account of uniqueness in its Strength to Weight ratio, Design, Weight and the Cost benefit.



DUCTILE IRON MANHOLE COVERS

We deal with an European ISO 9001: 2000 company has been working in the production of grey and ductile cast iron manhole covers, Gratings and DI Steps since the early 1980`s. As per BS EN124 in all traffic load range

The certifications issued by ICIM spa, the Institute of Certification belonging to the Italian Federation of Quality Systems (CISQ), internationally recognized by IQNET.

The products are checked in conformity to the certificate of inspection 3.1 B, according to European standard UNI EN 10204.

The products carry the "P-ICIM" mark, which is a guarantee about the working process in every phase:

The manufactures guarantee the principles of construction, testing, markings and inspecting prescribed by the norm EN 124:94 , which guarantees maximum production reliability

The products are checked in conformity to the certificate of inspection 3.1 B, according to European standard UNI EN 10204.

The products carry the "P-ICIM" mark, which is a guarantee about the working process in every phase:



FRP MANHOLE COVERS

- **FRP MANHOLE COVER (EN 124):** FRP Manhole Covers are made using thermoset material for long term durability. The material comprises of cross-linked polyesters combined with Fiberglass reinforced materials to sustain against wear-tear for heavy load vehicular traffic. It is 40% lighter than traditional Precast Concrete and CastIron covers. Provides upto 5 times more compressive strength. This resilient material withstands constant exposure to weather or sun without sacrificing security or aesthetics. sential FRP Gratings, Gully Covers, GRP Manhole Cover, Rust free, Light Weight, free from theft Manhole Covers. Frames on account of uniqueness in its Strength to Weight ratio, Design, Weight and the Cost benefit.

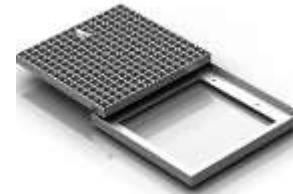

DUCTILE IRON PIPES & FITTING

Ductile Iron Pipe is made of ductile cast iron commonly used for potable water transmission and distribution.

The ductile iron used to manufacture the pipe is characterized by the spheroidal or nodular nature of the graphite within the iron, the pipe is manufactured using centrifugal casting in metal or resin lined moulds.

Protective internal linings and external coatings are often applied to ductile iron pipes to inhibit corrosion: the standard internal lining is cement, mortar and standard external coatings include bonded zinc, asphalt or water-based paint. In highly corrosive environments loose polyethylene sleeving (LPS) to encase the pipe may also be used.

Life expectancy of unprotected ductile iron pipes depends on the corrosiveness of soil present and tends to be shorter where soil is highly corrosive. However, a lifespan in excess of 100 years has been estimated for ductile iron pipelines installed using "evolved laying practices", including use of properly installed LPS (polyethylene encasement).



uPVC PIPES AND FITTINGS

uPVC is a thermoplastic material derived from common salt and fossil fuels. The pipe material has the longest track record of all plastic materials.. uPVC pipes are certified safe for drinking water per NSF Standard 61 and used extensively for water distribution and transmission pipelines throughout the world. uPVC is allowed for waste lines in homes and is the most often used pipe for sanitary sewers.

Further pressure and non-pressure applications in the field of sewers, soil and waste, gas (low pressure) and cable protection soon followed. The material's contribution to public health, hygiene and well-being has therefore been significant.

uPVC has high chemical resistance across its operating temperature range, with a broad band of operating pressures. Max operating temperature is reported at 140 °F (60 °C), and max working pressure: 450 psi (3,100 kPa). Due to its long-term strength characteristics, high stiffness and cost effectiveness, uPVC systems account for a large proportion of plastic piping installations



HDPE PIPES

HDPE PROFILE PIPES: HDPE Corrugated/ Spiral Pipes which is described as the world's best drainage pipes with Larger Diameters of Corrugated pipes are three layers which supports each other and its standard is DIN 16961 , ISO-9969, and ASTM F 894

Ranging from 300 mm - 4000 mm diameter

APPLICATIONS

- Storm, Rain and Melt Water Systems
- Gravity water Mains
- Culverts
- Drainage
- Cable Ducts
- Infrastructure application
- irrigation system
- Sewer lines and residential connections
- Treatment plant



HDPE PIPES

HDPE SOLID WALL Pipes: High-density polyethylene (HDPE) or polyethylene high-density (PEHD) is a polyethylene thermoplastic made from petroleum. It is sometimes called “Poly” or “polythene” when used for pipes. With a high strength-to-density ratio, PE Pipe is used in the production of corrosion-resistant piping, geomembranes, and plastic lumber.

Large diameter **HDPE pipe** has been used successfully in many installations worldwide. **High-density Polyethylene pipe** has proven itself in applications including:

- Water Supply
- Gas pipelines
- Drainage Systems
- Irrigation
- Gravity Sewers
- Hydroelectric
- Storm Drains & Sewers



IRRIGATION PIPINGS & SYSTEMS

Irrigation system installations consist of various pipes, fittings, valves and other equipment depending on the kind of system and the type of installation. Most installations have the same structure, and thus a relatively small range of equipment can meet the requirements of a whole region. Irrigation equipment can be divided into:

- pipes
- pipe connector fittings;
- flow control devices
- filters;
- fertigation equipment;
- water emitters;
- automation equipment;
- operation equipment;
- water-lifting devices.

The main characteristics of the irrigation equipment are:

- material are galvanized steel, rigid PVC, etc.;

- size, i.e. the nominal diameter (DN) of the ISO metric range in millimeters (16–160 mm)
- type of joint, e.g. threaded, quick coupling, solvent welded
- working pressure PN (nominal pressure) or PR (pressure rating) in bars, e.g. 6.0 bars;
- international standards conformed to, e.g. DIN, ISO, BS, ASTM, EN. The working pressure



HDPE FITTINGS

INJECTION MOULDED FITTINGS: Injection molded PE fittings are manufactured in sizes through 12-inch nominal diameter. Typical molded fittings are tees, 45° and 90° elbows, reducers, couplings, caps, flange adapters and stub ends, branch and service saddles, and self-tapping saddle tees.

FABRICATED FITTINGS Fabricated fittings are constructed by joining sections of pipe, machined blocks, or molded fittings together to produce the desired configuration. Components can be joined by butt or socket heat fusion, electrofusion, hot gas welding or extrusion welding techniques.

THERMOFORMED FITTINGS Thermoformed fittings are manufactured by heating a section of pipe and then using a forming tool to reshape the heated area

ELECTROFUSION COUPLINGS Electrofusion couplings and fittings are manufactured by either molding in a similar manner as that previously described for butt and socket fusion fittings or manufactured from pipe stock.

Injection Molded Couplings The external coupling body is typically injection molded and upon final assembly will include internal components such as steel stiffeners, O-rings, gripping collets, and other components depending upon the design



HDPE MANHOLES

HDPE MANHOLES: Manholes, sumps, tanks and other structures are constructed from both solid wall HDPE pipe and profile pipe. They are leak-free, lightweight and offer excellent chemical resistance. Manholes/Sumps and other structures are available in the following sizes.

APPLICATION

- **STORMWATER MANHOLES**
- **CHLORINATION CHAMBERS**
- **SANITARY MANHOLES**
- **HOUSE CONNECTION CHAMBERS**
- **INSTRUMENT CHAMBERS**
- **VALVE CHAMBERS**
- **VACUUM CHAMBERS**
- **HDPE TANKS**



GRP TANKS

Glass Reinforced Plastics) is a modern composite material of construction for chemical plant, pulp and paper mill, and food and pharmaceutical equipment like tanks and vessels. Chemical equipment that range in size from less than a metre to 20 metres are fabricated using GRP as material of construction.

GRP Chemical Equipment are manufactured mainly by Hand Lay-up and filament winding processes. BS4994 is a key standard for this class of items.

GRP tanks and vessels designed as per BS 4994 are widely used in the chemical industry in the following sectors: chlor-alkali manufacturers, fertilizer, wood pulp and paper, metal extraction, refining, electroplating, brine, vinegar, food processing, and in air pollution control equipment, especially at municipal waste water treatment plants and water treatment plants.

GRP tanks and process vessels are used in various commercial and industrial applications, including chemical, water & wastewater, food & beverage, mining & metals, power, energy, and high-purity applications.



HDPE TANKS

HDPE WATER/CHEMICAL TANKS the most common, economical above ground tank style is the vertical cylinder style, Polyethylene storage tanks sizes range from 100 ltrs up to 100000 ltrs.

STYLE OF TANK

Each style of tank has its own best suited application:

- **VERTICAL WATER TANKS**
- **BOX TANKS**
- **TAPER TANKS**
- **ONE BOTTOM TANKS**
- **LEG TANKS**
- **UTILITY TANKS**
- **CISTERN TANKS**
- **SEPTIC TANKS**
- **HDPE SEPTIC TANK**



VALVES

VALVE is a device that regulates, directs or controls the flow of a fluid (gases, liquids, fluidized solids, or slurries by opening, closing, or partially obstructing various passageways. Valves are technically fittings but are usually discussed as a separate category. In an open valve, fluid flows in a direction from higher pressure to lower pressure.

MATERIAL OF CONSTRUCTION

- Ductile Iron
- Cast Iron
- Carbon Steel
- Stainless Steel
- Cast Steel
- Duplex Stainless Steel



TYPES OF VALVES

- Ball Valve
- Butterfly Valve
- Ceramic Disc Valve
- Clapper Valve
- Check Valve or Non-Return Valve
- Choke Valve
- Diaphragm Valve
- Dismantling Joints
- Expansion Joints
- Gate Valve
- Globe Valve
- Hydrants
- Knife Valve
- Needle Valve
- Penstock Valves
- Pinch Valve
- Pipe Saddle for uPVC
- Piston Valve
- Plug Valve/PE
- Poppet Valve
- Spool Valve
- Thermal Expansion Valve.
- Pressure Reducing Valve
- Sampling Valves
- Safety Valve



PUMPS

PUMP: is a device that moves liquids or gases or slurries by mechanical action. Pumps can be classified into three major groups according to the method they use to move the fluid: direct lift, displacement, and gravity pumps

Mechanical pumps serve in a wide range of applications such as pumping water from wells, aquarium filtering, pond filtering and aeration, in the car industry for water-cooling and fuel injection, in the energy industry for pumping oil and natural gas or for operating cooling towers

OUR RANGE OF PUMPS

- **RAW WATER PUMPS**
- **CLEAR WATER PUMP**
- **DEWATERING PUMPS**
- **SEWAGE PUMPS**
- **WASTE WATER PUMPS**
- **SLURRY PUMPS**



FIRE FIGHTING SYSTEMS

- FIRE PUMPS SYSTEMS
- EXTINGUISHING & SUPPRESSION SYSTEM
- FOAM SYSTEMS & EQUIPMENTS
- FIRE HYDRANTS & ACCESSORIES
- FIRE DOOR ASSEMBLIES
- FIRE CABINETS
- FIRE HOSE & ACCESSORIES
- FIRE EXTINGUISHERS
- FIRE DETECTION & ALARM SYSTEMS
- VALVES & SPRINKLERS
- STANDPIPES SYSTEMS
- FIRE BLANKETS
- OTHER FIRE FIGHTING EQUIPMENTS



DG SETS

A **diesel generator** is the combination of a diesel engine with an electric generator (often an alternator) to generate electrical energy. This is a specific case of engine-generator. A diesel compression-ignition engine is usually designed to run on diesel fuel, but some types are adapted for other liquid fuels or natural gas.

Diesel generating sets are used in places without connection to a power grid, or as emergency power-supply if the grid fails, as well as for more complex applications such as peak-opping, grid support and export to the power grid.

Proper sizing of diesel generators is critical to avoid low-load or a shortage of power. Sizing is complicated by the characteristics of modern electronics, specifically non-linear loads. In size ranges around 50 MW for regular part-loading, even at these power levels, diesel arrays are sometimes preferred to open cycle gas turbines, due to their superior efficiencies.



TRANSFORMER

TRANSFORMERS Industrial" refers to **industrial-grade electrical transformers** that are specifically designed for the demanding conditions and high-capacity power needs of manufacturing, mining, oil & gas, and other heavy industries.

Types of Industrial Transformers

- ❖ Industries use a variety of transformer types, each optimized for specific functions:
- ❖ **Power Transformers:** Large units used in substations and power plants to transmit power over long distances or integrate renewable energy into the grid.
- ❖ **Distribution Transformers:** Used to distribute electricity from the main source to various points within a facility, stepping down voltage for general use
- ❖ **Isolation Transformers:** Electrically separate the supply and load circuits to prevent electric shock, eliminate noise, and protect sensitive equipment.
- ❖ **Furnace Transformers:** Provide high current and low voltage for electric arc and induction furnaces in the metallurgical industry.
- ❖ **Control Transformers:** Designed to reduce supply voltages to the control voltages necessary for operating loads such as relays, solenoids, and timers in control panels.
- ❖ **Rectifier Transformers:** Used in conjunction with rectifiers to convert AC power to DC power for applications like aluminium electrolysis or variable speed drives



HDPE WELDING MACHINES

Plastic Welding is welding for semi-finished plastic materials and is described in ISO 472 as a process of uniting softened surfaces of materials, generally with the aid of heat.

Welding of thermoplastics is accomplished in three sequential stages, namely surface preparation, application of heat and pressure, and cooling. Numerous welding methods have been developed for the joining of semi-finished plastic materials. Based on the mechanism of heat generation at the welding interface, welding methods for thermoplastics can be classified as external and internal heating methods

WELDING METHOD

- **Butt Fusion Welding**
- **Extrusion Welding**
- **Electrofusion Welding**
- **Hot Gas Welding**



G.I GRATINGS & GUARD RAILS

A grating is any regularly spaced collection of essentially identical, parallel, elongated elements. Gratings usually consist of a single set of elongated elements, but can consist of two sets, in which case the second set is usually perpendicular to the first (as illustrated). When the two sets are perpendicular, this is also known as a grid (as in grid paper) or a mesh.

Guard rail, guardrails, or protective guarding, in general, are a boundary feature and may be a means to prevent or deter access to dangerous or off-limits areas while allowing light and visibility in a greater way than a fence. Common shapes are flat, rounded edge, and tubular in horizontal railings, whereas tetra form spear-headed or ball-finialled are most common in vertical railings around homes. Park and garden railings commonly in metalworking feature swirls, leaves, plate metal areas and/or motifs particularly on and beside gates.

- High security railings (particularly if in flat metal then a type of palisade) may instead feature jagged points and most metals are well-suited to anti-climb paint.
- A handrail is less restrictive on its own than a guard rail and provides support



TOWERS

Telecommunications towers are radio masts and towers built primarily to hold telecommunications antennas. As such antennas often have a large area and must be precisely pointed out, such towers have to be built so, that they do not much swing in the wind. So very stable structure types like low lattice towers and towers built of reinforced concrete are used in most cases, although also guyed masts are used.

- Different types of towers may be built based on requirements. These could be:
- Lattice type (as mentioned above) - where a large number of antennas need to be mounted
- Guyed towers - designed for ease of use and to provide versatility
- Monopole towers - where space, zoning, or weather restrictions apply
- Camouflage towers - where the visual impact of the tower needs to be reduced
- Self-support towers - most flexible and usable for most wireless applications
- Mobile cell towers - used for temporary requirements.



AFTER SALES SERVICE

- ❖ With our expertise in water & waste water ,plumbing , Civil Engineering , Mining and Engineering , Electricals Industries and our tremendous connections with Private sector ,consultants & contractors
- ❖ Design and Engineering
- ❖ Selection of right equipment and material wrt to specification given'
- ❖ Quality products
- ❖ Supply and Installation
- ❖ After Sales & Services
- ❖ Supply of spare Parts and Consumables
- ❖ Trouble Shooting
- ❖ Repair ,modify , re install a non working system of any make
- ❖ Timely execution of projects
- ❖ Training of services staff



CLIENTS

- ❖ WASAC (CCECC Project)
- ❖ Tolirwa Kigali Rwanda
- ❖ Mulindi Tea Garden Rwanda
- ❖ Shagasha Tea Garden Rwanda
- ❖ REMCO Rwanda
- ❖ Rugabano Tea Garden Rwanda
- ❖ PDO, Oman
- ❖ British Petroleum, Oman
- ❖ Ministry of Interior Oman
- ❖ Halliburton Oman
- ❖ Ministry of Defense , Oman
- ❖ Dhofar Municipality, Oman
- ❖ Sohar Municipality, Oman
- ❖ Muscat Municipality, Oman
- ❖ Haya Water, Oman
- ❖ Emirates Airlines, UAE
- ❖ ALSA Engineering, UAE
- ❖ National Guard , KSA
- ❖ Prince Naif Palace,
- ❖ Stevin Rock UAE
- ❖ ESAB UAE
- ❖ Suhail Al Mazroi Group UAE
- ❖ Dubai sports city UAE
- ❖ Nigeria Power Plant Ibese Africa
- ❖ Somalia Mogadishu Camp, Africa
- ❖ Benin Power Plant, Africa
- ❖ Nova Machinery , Lesotho Africa
- ❖ Nova Machinery, Rwanda, Africa
- ❖ Nova Machinery , South Africa
- ❖ Nova Machinery , Nigeria Africa
- ❖ Al Jaber group UAE
- ❖ DEWA UAE
- ❖ SEWA UAE
- ❖ FEWA UAE
- ❖ PAEW Oman
- ❖ Muscat Airport , Oman
- ❖ Salalah Airport , Oman
- ❖ L & T , Oman



PARTNERS IN

AFRICA



ASIA & MIDDLE EAST



EUROPE



CONTACT US



DANYOU ENGINEERING & TRADING RWANDA LTD

G-01-02 KN 8 AVENUE ,

KINAMBA , KACYIRU,

KIGALI CITY , RWANDA

MOB No : +250785778480

EMAIL : info@danyouengineers.co.in

WEB: www.danyouengineers.co.in



“Waste is not waste until we waste it”

Thank You

DANYOU ENGINEERING & TRADING RWANDA LTD